

ARTICOLO / Item  
Artículo / Article / Artikel

02064

R2

Rubinetto a pedale per montaggio a parete.

Foot operated tap, wall mounted type.

Grifo a pedal fijación mural.

Robinet simple à pédale fixation murale.

Pedalarmatur mit Fußbedienung, wandmontiert.

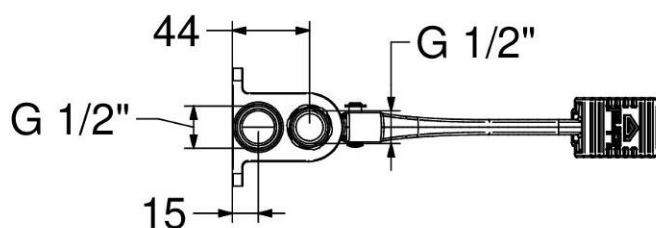
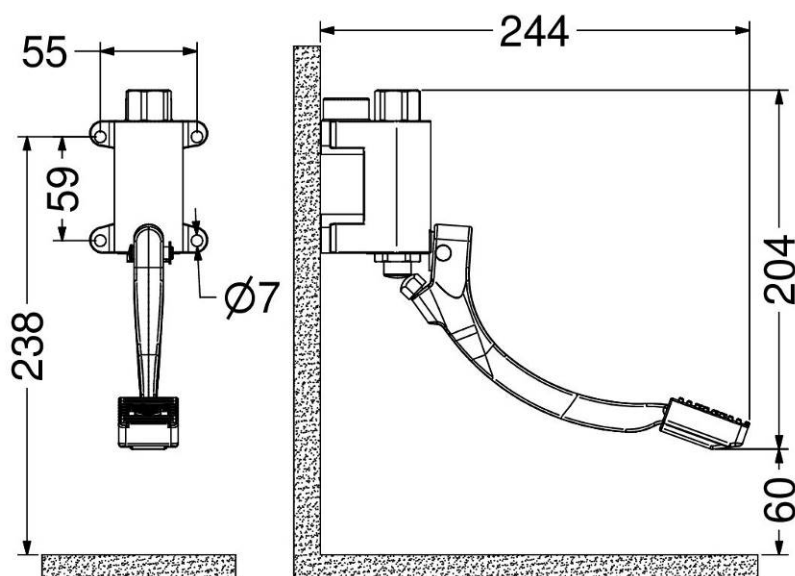

IT



#### COMPOSIZIONE

- Corpo pedale in ottone cromato
- Leva in ottone con copripedale in gomma
- Kit di fissaggio
- Guarnizione con filtro 1/2"

#### CARATTERISTICHE FUNZIONALI

**Pressione di alimentazione:** Min 0.5 – max 8 bar

**Temperatura di alimentazione:** 5 – 65 °C

EN



#### COMPOSITION

- Chromed brass tap's body
- Brass lever with rubber cover
- Fixing kit
- 1/2" joint with filter

#### OPERATING CHARACTERISTICS

**Operating pressure:** Min 0.5 – max 8 bar

**Water inlet temperature:** 5 – 65 °C

ES



#### CARACTERÍSTICAS

- Cuerpo pedal en latón cromado
- Palanca en latón y cobertura en goma
- Kit de fijación
- Junta con filtro 1/2"

#### CARACTERÍSTICAS FUNCIONALES

**Presión de alimentación:** Min 0.5 – max 8 bar

**Temperatura de alimentación:** 5 – 65 °C

FR



#### CARACTÉRISTIQUES

- Corps pédale en laiton chrome
- Levier en laiton avec couverture en caoutchouc
- Kit de fixation
- Joint avec filtre 1/2"

#### CARACTÉRISTIQUES FONCTIONNELLES

**Pression d'alimentation:** Min 0.5 – max 8 bar

**Température d'alimentation:** 5 – 65 °C

DE



#### LIEFERUMFANG

- Körper aus verchromten Messing
- Pedal aus Messing mit Gummiüberzug
- Fixierungsset
- Dichtung mit Filter 1/2"

#### FUNKTIONELLE EIGENSCHAFTEN

**Zulaufdruck:** min. 0.5 – max. 8 bar

**Zulauftemperatur:** 5 – 65 °C

